

# ***GrateWalk™ Rooftop Walkways with Integrated Dura Blok™ Supports***

Cooper B-Line GrateWalk Rooftop Walkways with Dura-Blok provides the optimal solution to extend the life of your roof, while providing a safe pathway to roof mounted support equipment. The self cleaning GrateWalk pattern creates an ideal walking surface in all weather conditions. The Dura-Blok supports are made from 100% recycled rubber, require no supplemental rubber pads, and will not float or blow away. The result is an easy to install walkway that helps reduce the need for roof maintenance.



## **Features & Benefits of the GrateWalk Rooftop Walkway**

- Safety Grating is available with slip resistant Grate-Lock™, helping provide a safe walkway for foot traffic on the roof.
- Easy to install, elevated design, creates an identifiable path for foot traffic helping prevent wear and tear to the roof surface.
- The cross-over design offers safe passage over existing cabling, piping, cable tray or any other interference on the rooftop.
- The self cleaning pattern allows water and dirt to easily flow through, helping make the grating an ideal walkway in all weather conditions.
- Handrail options are available

## **The Added Benefit of the Dura-Blok Supports**

- Integrated with 100% post-consumer recycled rubber supporting LEED credit qualification.
- Provide solid support for the walkway that stays in place and replaces the need for separate rubber roof mounting pads which tend to float away.

**Safety Grating • BA199SG**

# GrateWalk™ Rooftop Walkways with Integrated Dura Blok™ Supports

The GrateWalk Rooftop Walkway with Integrated Dura-Blok Supports\* is available in a variety of configurations.

- Straight Sections for long straight stretches of pathway
- Cross-over options to install over the existing cable trays, piping, and more
- Stairways over the top of existing equipment or leading up to existing equipment
- Handrail options available for additional walkway safety and support
- Platforms to provide access to rooftop mounted equipment
- Accessories available to support unique requirements

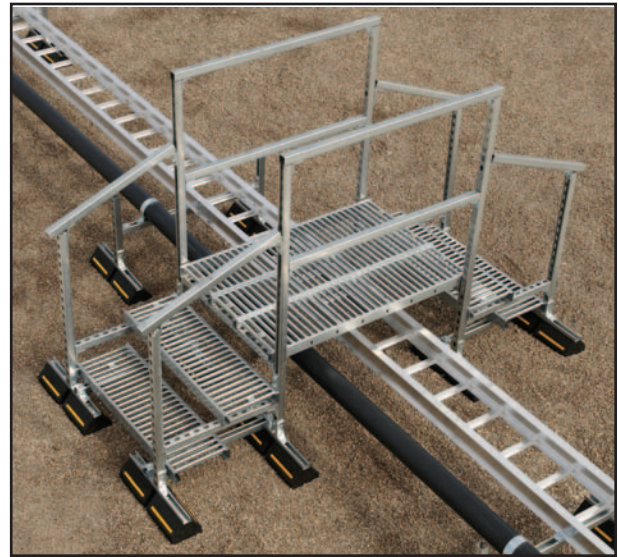

\* All Items are shipped individually for field assembly.

Figure A

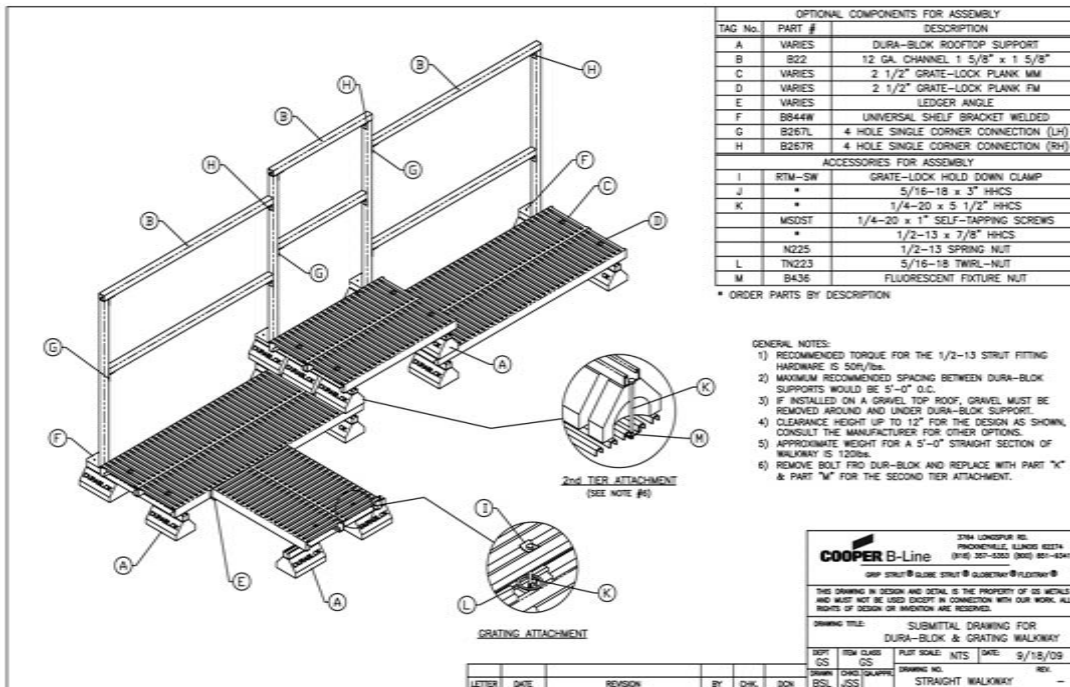

## Cooper B-Line Engineering Design Services

- Take-off and estimating
- Specification review and development
- Alternative layout designs
- Technical consultation
- Submittal drawing packages (see Figure A) including assembly instructions

For additional information or technical assistance, contact Cooper B-Line Tech Services  
 Phone: 800-851-9341 • Fax: 770-268-7213

www.cooperbline.com