

# Croc-Lok™ Box Mounting Bracket

Field installed in less than four (4) seconds



*“The Best Pre-Fab Mounting Bracket on the Market”*  
Includes added features for support and installation.



Patent Pending

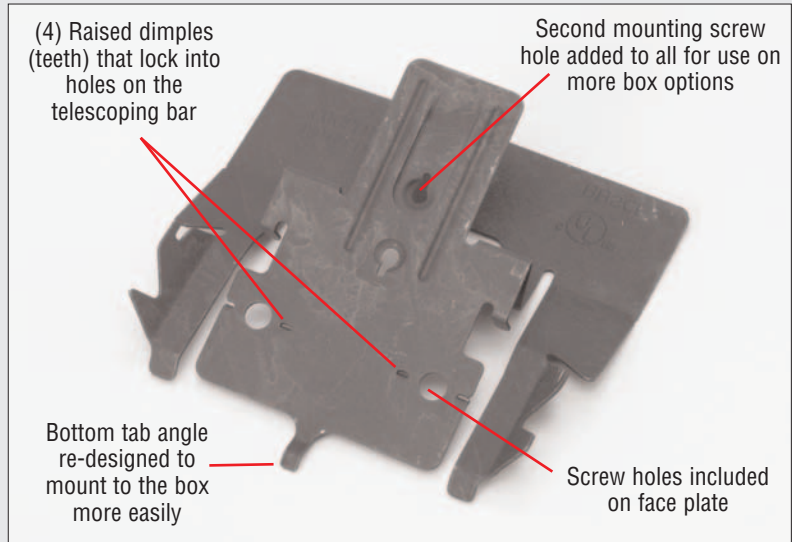

## Features

- The Croc-Lok Box Mounting Bracket is an improved version of the current BB2TS Slider Bracket.
- The Croc-Lok reduces installation time - its tool-less design allows installers to simply squeeze, secure and walk away.
- The narrow width of the Croc-Lok allows for up to three - 4" boxes to be installed within a 16" stud spacing, and up to four - 4" boxes within a 24" stud spacing.
- Its design offers placement flexibility by locking in place firmly at any position along the telescoping bar. The Croc-Lok can be attached before or after the telescoping bracket is mounted to the stud wall.

UPC/Part Number	Catalog Number	Stud Spacing	Description	Box Qty.
78205151291	BB2CL	NA	Croc-Lok Bracket Only	50
78205154019	BB2CL-4DN	NA	Croc-Lok Bracket w/ 4" Sq. - Deep Box	NA
78205151292	BB216TCL	11" to 18"	BB2-16T with Croc-Lok Bracket	20
78205151293	BB224TCL	15" to 26"	BB2-24T with Croc-Lok Bracket	25

- Note:**
- The Croc-Lok secures to Cooper B-Line BB216T and BB224T telescoping brackets only.
  - For a standard 2<sup>1</sup>/<sub>8</sub>" deep box, the stud depth must be 3<sup>1</sup>/<sub>2</sub>" or greater.
  - For a shallow 1<sup>1</sup>/<sub>2</sub>" deep box, the stud depth must be 2<sup>1</sup>/<sub>2</sub>" or greater.

Fasteners • BA184F

# BB216TCL - 2 10 4D A - - - - -

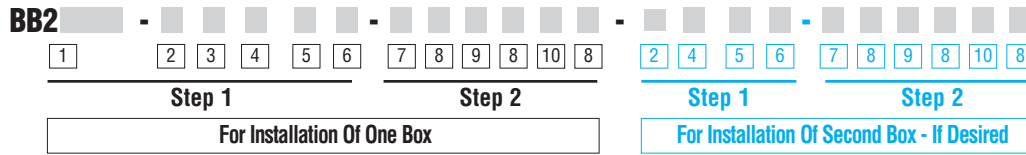

## Step 1 - Basic Ruff-In

### 1 Stud Spacing

- BB216TCL = 11" - 18" Mtg. Bar & Croc-Lok assembly
- BB224TCL = 15" - 25" Mtg. Bar & Croc-Lok assembly
- BB2CL = Croc-Lok assembly only

### 2 Plaster Ring Style

- 1 = One Device
- 2 = Two Device
- R = Round
- 1AJ = One Device Adjustable \*
- 2AJ = Two Device Adjustable \*\*
- Blank = Box Only

### 3 Plaster Ring Size

- 04 = 1/4" Raise
- 08 = 1/2" Raise
- 10 = 5/8" Raise
- 12 = 3/4" Raise
- 16 = 1" Raise
- 20 = 1 1/4" Raise
- 24 = 1 1/2" Raise
- 32 = 2" Raise
- Blank = Box Only or Adjustable Plaster Ring

## Step 1 - Basic Ruff-In (cont.)

### 4 Box Style

- 4D = 4" Sq., 2 1/8" Deep
- 436 = 4" Sq., 2 1/8" Deep, 1" KO
- 4 = 4" Sq., 1 1/2" Deep
- 432 = 4" Sq., 2 1/8" Deep, 3/4" KO
- 5D = 4 11/16" Sq., 2 1/8" Deep
- 560 = 4 11/16" Sq., 2 1/8" Deep, 1" KO
- 5 = 4 11/16" Sq., 1 1/2" Deep
- 554 = 4 11/16" Sq., 2 1/8" Deep, 3/4" KO

### 5 Ground Wire

(Pre-installed devices require stranded wire)

- Blank = Solid Ground Wire
- A = Stranded Ground Wire
- N = No Ground Wire

### 6 Firestop Pad

- Blank = No Pad
- F = Pad Installed

## Step 2 - Connectors

### 7 Connector Top Left KO

- Blank = No Attachment
- L = Attachment Present

### 8 Connector Type

- Blank = None
- A = QLK50S (1/2" single MC)
- B = QLK50D (1/2" double MC)
- C = QLK75 (3/4" single MC)
- D = SSBC50 (1/2" EMT Connector)
- E = SSBC75 (3/4" EMT Connector)
- F = SSBC100 (1" EMT Connector)

### 9 Connector Top Middle KO

- Blank = No Attachment
- M = Attachment Present

### 10 Connector Top Right KO

- Blank = No Attachment
- R = Attachment Present

For wiring device assemblies, refer to Ruff-IN Brochure (BLFRI-09)

The Croc-Lok is a versatile addition to the Ruff-IN pre-fab product family. The following options are available.

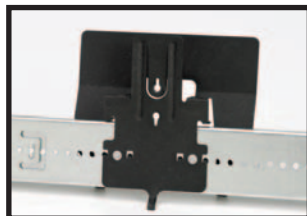

Purchased alone or combined with the telescoping bracket to be used in contractor pre-fab shops.



As a complete assembly, which includes the Croc-Lok, Telescoping Bracket, and connectors or wiring devices installed.

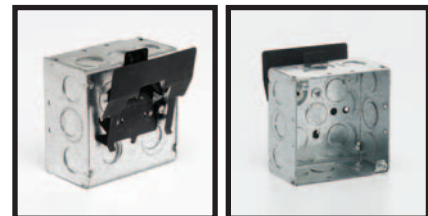

Also available: Croc-Lok box assemblies sold without telescoping bars. To reduce the lines on your BOM consider ordering Croc-Lok box assemblies and field install.

- Basic Ruff-IN = 3-5 day lead-time for quantities of 1000 or less.
- Ruff-IN with Wiring Devices = 10-15 day lead-time for quantities of 500 or less.
- Non Stock Components = Call factory for lead-time.

Phone: 800-851-7415 • www.cooperbline.com